



surflo

Flow Monitor

B2900 Series

DESCRIPTION

The B2900 flow monitor incorporates state-of-the-art, digital signal processing technology, designed to provide exceptional flexibility at a very affordable price. Though it is designed for use with Blancett flow sensors, this monitor can be used with almost any flow sensor producing a low amplitude AC output or contact closure signal.

OPERATION

This monitor can accept low-level frequency input signals typically found in turbine flow sensors. The output signal for these types of sensors is a frequency proportional to the rate of flow. The B2900 monitor uses the frequency information to calculate flow rate and total flow. Through the use of the programming buttons, you can select rate units, total units and unit time intervals among other functions. If required, the monitor can easily be re-configured in the field. Finally, you can choose between simultaneously showing rate and total, or alternating between rate and grand total.

The monitor provides advanced communication capabilities over an RS485 bus using Modbus RTU and control outputs.

The package is a polycarbonate NEMA 4X enclosure.

APPLICATIONS

The B2900 monitor is suitable for application in a wide variety of metering needs. A few of the more common industries are:

- Secondary oil recovery applications
- Remediation and reclamation
- Fracture/refracture
- Coal bed methane
- Regulatory compliance and environmental accountability
- Industrial chemicals
- Aggressive chemical processing applications
- Semiconductor manufacturing
- Fertilizer production and dispensing
- Pesticide manufacture
- Liquid batching and water cooling



FEATURES

- Robust alarm parameters provide faster warning when something changes in the process or pipeline.
- Greater control and greater visibility of batch operations.
- Advanced connectivity options allow you to connect meters to your network for remote monitoring and process automation capabilities.
- Updated display and totalization options provide more flow information, including simultaneous display of rate and total as well as standard, batch and grand totals.
- Various mounting options provide a B2900 model for your operation.

PART NUMBER CONSTRUCTION

Blancett B2900 Display	<input type="text"/>	<input type="text"/>	<input type="text"/>	-	<input type="text"/>
Model					
Blancett B2900 Display	B29				
Model					
Advanced		A			
Mounting					
Meter					M
Remote					R
Swivel					S
Units of Measure					
Customer Selectable					CS

SPECIFICATIONS

Display	Common	Simultaneously shows Rate and Total 5 x 7 Dot Matrix LCD, STN Fluid			
	6 Digit Rate, 0.5 inch (12.7 mm) numeric				
	7 Digit Total, 0.5 inch (12.7 mm) numeric				
	Engineering Unit Labels 0.34 in. (8.6 mm)				
	Annunciators	Alarm 1 (A), Alarm 2 (B), Battery Level (■■■■■), RS485 Communications (COM)			
Power	Auto switching between internal battery and external loop power; includes isolation between loop power and other I/O				
	Battery	3.6V DC lithium D Cell gives up to 6 years of service life Note: Modbus enabled at baud rate of 19,200 or higher without loop power reduces battery life to 1 year			
	Loop	4...20 mA, two wire, 25 mA limit, reverse polarity protected, 7V DC loop loss			
Inputs	Magnetic Pickup	Frequency Range	1...3500 Hz		
		Frequency Measurement Accuracy	±0.1%		
		Over Voltage Protection	28V DC		
		Trigger Sensitivity	30 mV _{pp} (High) or 60 mV _{pp} (Low) - (selected by circuit board jumper)		
	Amplified Pulse	Direct connection to amplified signal (pre-amp output from sensor)			
Outputs	Analog 4...20 mA	4...20 mA, two-wire current loop 25 mA current limit			
	Totalizing Pulse	One pulse for each Least Significant Digit (LSD) increment of the totalizer			
		Pulse Type (selected by circuit board jumper)	Opto-isolated (Iso) open collector transistor		
			Non-isolated open drain FET		
		Maximum Voltage	28V DC		
		Maximum Current Capacity	100 mA		
	Maximum Output Frequency	16 Hz			
	Pulse Width	30 mSec fixed			
	Status Alarms	Type	Open collector transistor Adjustable flow rate with programmable dead band and phase.		
		Maximum Voltage	28V DC		
Maximum Current		100 mA			
Pullup Resistor		External required: 2.2 k ohm minimum, 10 k ohm maximum			
Modbus Digital Communications	Modbus RTU over RS485, 127 addressable units / 2-wire plus ground network, selectable baud rate: 9600, 19200, 38400, 57600 or 115200, long integer and single precision IEEE754 formats; retrieve: flow rate, job totalizer, grand totalizer, alarm status and battery level; write: reset job totalizer, reset grand totalizer				
Data Configuration and Protection	Two four-digit user selectable passwords; level one password enables job total reset only, level two password enables all configuration and totalizer reset functions				
Certifications	Safety	Intrinsically Safe Class I Division 1, Groups C, D; Class II, Division 1 Groups E, F, G			
	Entity Parameters	4...20 mA Loop: Vmax = 28V DC	Imax = 26 mA	Ci = 0.5 µF	Li = 0 mH
		Pulse Output: Vmax = 28V DC	Imax = 100 mA	Ci = 0 µF	Li = 0 mH
		Reset Input: Vmax = 5V DC	Imax = 5 mA	Ci = 0 µF	Li = 0 mH
		RS485: Vmax = 10V DC	Imax = 60 mA	Ci = 0 µF	Li = 0 mH
		Turbine Input: Voc = 2.5V	Isc = 1.8 mA	Ca = 1.5 µF	La = 1.65 H
EMC	IEC61326-1; 2004/108/EC				
Measurement Accuracy	Common Accuracy	0.05%			
Response Time (Damping)	Common Response Time	1...100 seconds response to a step change input, user adjustable			
Environmental Limits	Common Limits	-22...158° F (-30...70° C); 0...90% humidity, non-condensing;			
Materials and Enclosure Ratings	Polycarbonate, stainless steel, polyurethane, thermoplastic elastomer, acrylic; NEMA 4X/IP 66 meter, remote and swivel mount; NEMA/UL/CSA Type 4X (IP-66)				
Engineering Units	Liquid	US Gallons, Liters, Oil Barrels (42 gallon), Liquid Barrels (31.5 gallon), Cubic Meters, Million Gallons, Cubic Feet, Million Liters, Acre Feet			
	Gas	Cubic Feet, Thousand Cubic Feet, Million Cubic Feet, Standard Cubic Feet, Actual Cubic Feet, Normal Cubic Meters, Actual Cubic Meters, Liters			
	Rate Time	Seconds, minutes, hours, days			
	Totalizer Exponents	0.00, 0.0, X1, x10, x100, x1000			
	K-factor Units	Pulses/US Gallon, Pulse/cubic meter, pulses/liter, pulses/cubic foot			

MOUNTING OPTIONS AND DIMENSIONS

Meter Mount

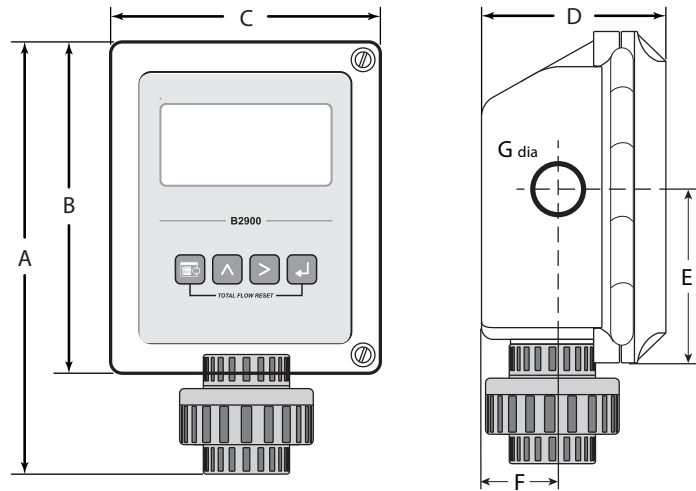

A	B	C	D	E	F	G dia
9.25 in. (235.0 mm)	7.00 in. (177.8 mm)	5.75 in. (146.0 mm)	4.00 in. (101.6 mm)	3.45 in. (87.6 mm)	1.50 in. (38.1 mm)	0.875 in. (22.2 mm)

Remote Mount

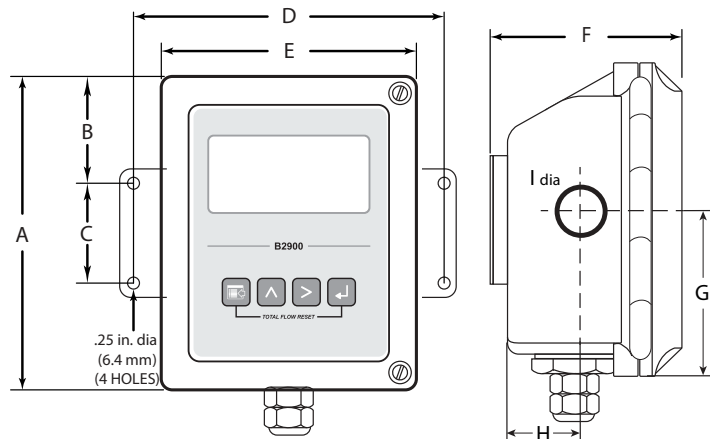

A	B	C	D	E	F	G	H	I dia
7.00 in. (177.8 mm)	2.40 in. (61.0 mm)	2.25 in. (57.2 mm)	7.00 in. (177.8 mm)	5.75 in. (146.0 mm)	4.38 in. (111.2 mm)	3.45 in. (87.6 mm)	1.50 in. (38.1 mm)	0.875 in. (22.2 mm)

Swivel Mount

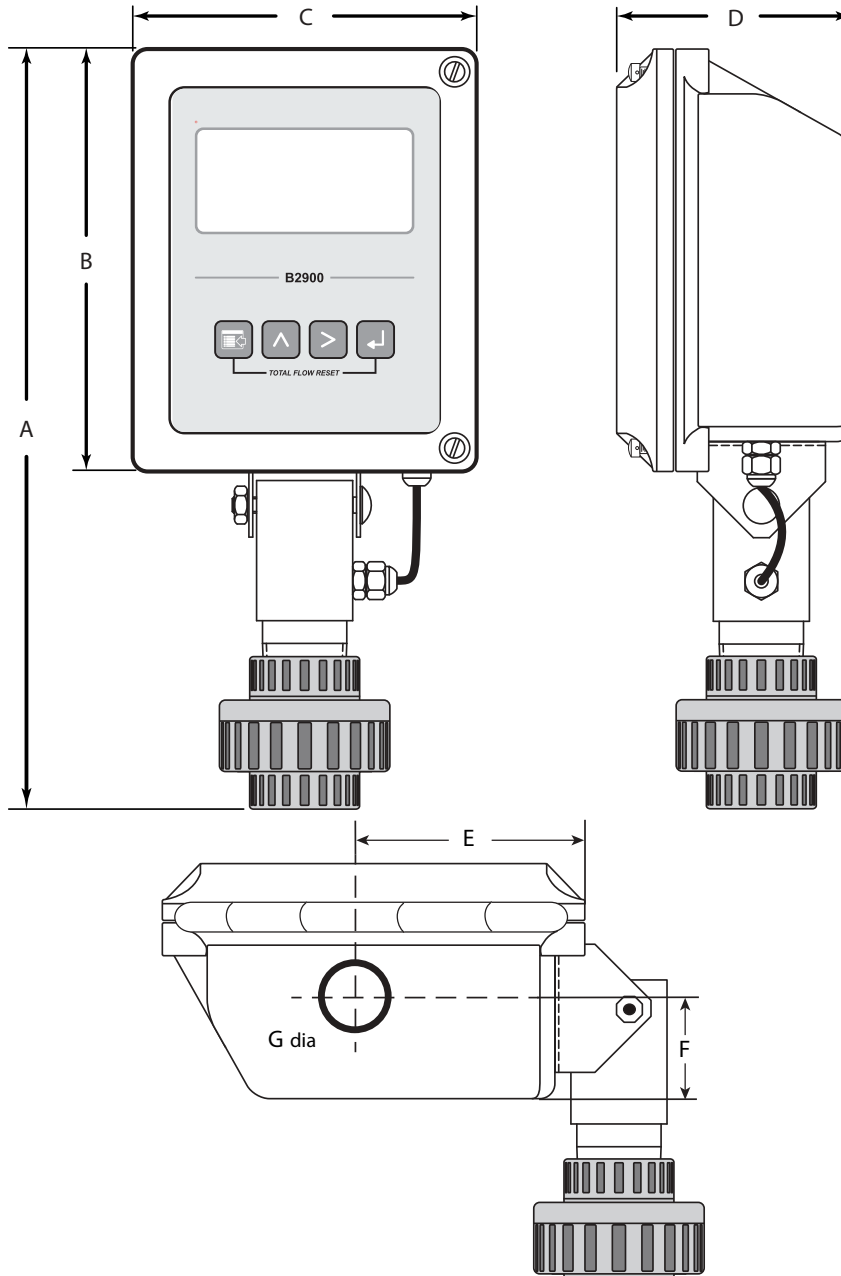

A	B	C	D	E	F	G dia
12.25 in. (311.2 mm)	7.00 in. (177.8 mm)	5.75 in. (146.0 mm)	4.00 in. (101.6 mm)	3.45 in. (87.6 mm)	1.50 in. (38.1 mm)	0.875 in. (22.2 mm)



surflo